

## LGV High Volume

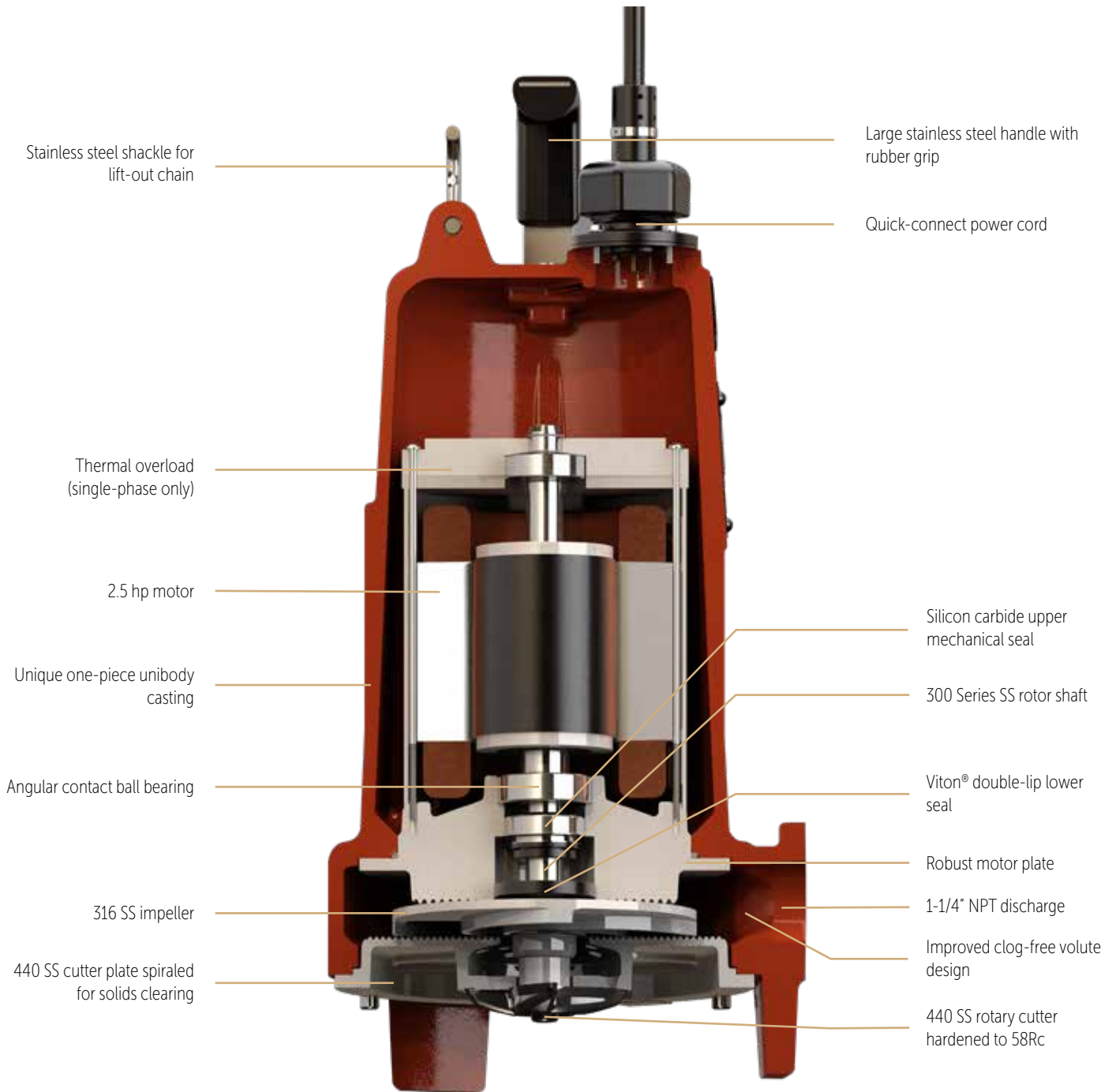

Patent: See  
[www.LibertyPumps.com/LEP/patents](http://www.LibertyPumps.com/LEP/patents)

## LGH High Head

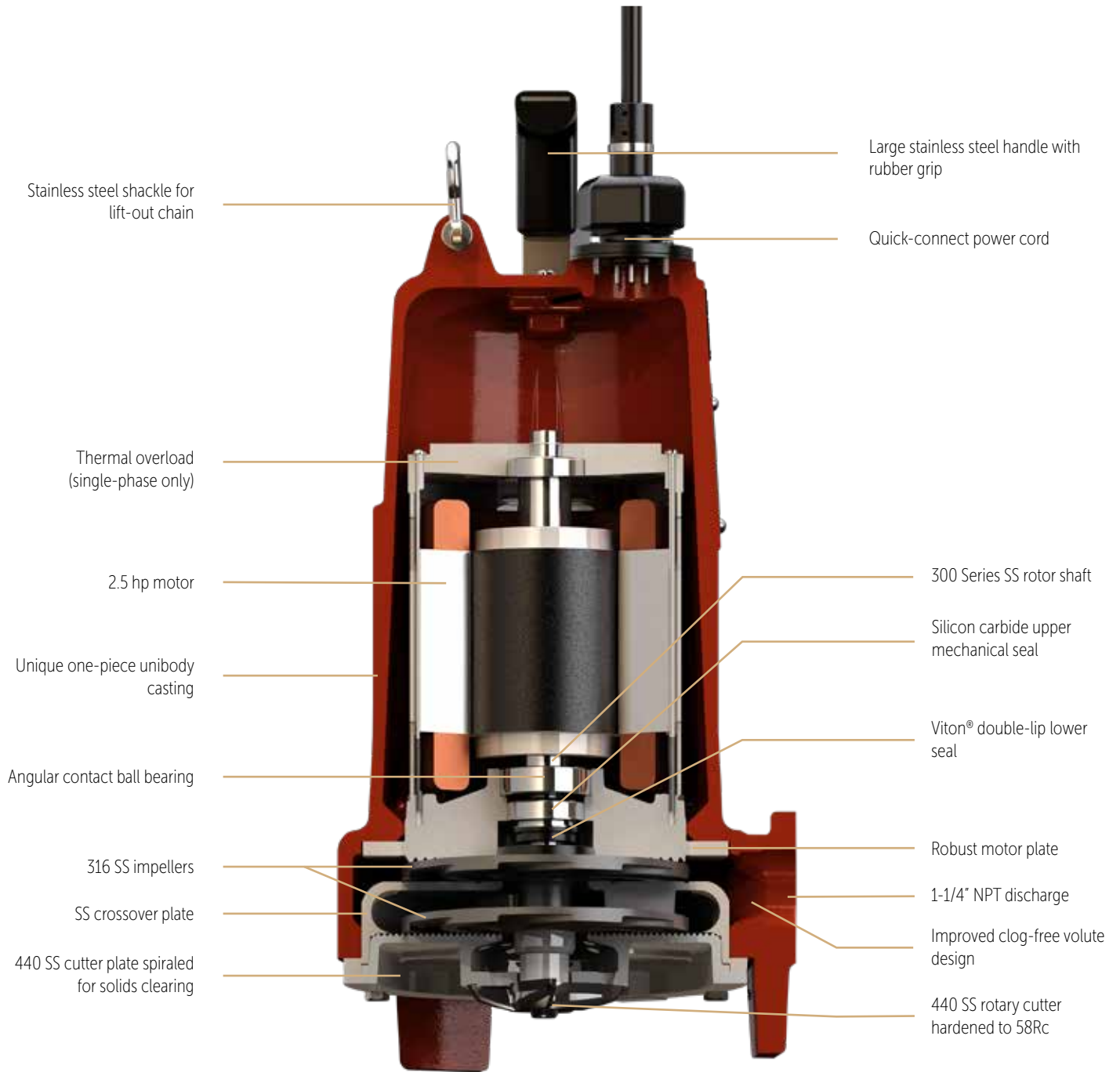

Stainless steel shackle for lift-out chain

Large stainless steel handle with rubber grip

Quick-connect power cord

Thermal overload (single-phase only)

2.5 hp motor

300 Series SS rotor shaft

Unique one-piece unibody casting

Silicon carbide upper mechanical seal

Angular contact ball bearing

Viton® double-lip lower seal

316 SS impellers

Robust motor plate

SS crossover plate

1-1/4" NPT discharge

440 SS cutter plate spiraled for solids clearing

Improved clog-free volute design

440 SS rotary cutter hardened to 58 Rc

Patent: See [www.LibertyPumps.com/LEP/patents](http://www.LibertyPumps.com/LEP/patents)

Model Number	LGH028	LGH022	LGH023	LGH024	LGH025	LGV028	LGV022	LGV023	LGV024	LGV025
HP	2.5	2.5	2.5	2.5	2.5	2.5	2.5	2.5	2.5	2.5
Volts	200	230	200/230	460	575	200	230	200/230	460	575
Phase	1*	1*	3	3	3	1*	1*	3	3	3
Hz	60	60	60	60	60	60	60	60	60	60
RPM	3450	3450	3450	3450	3450	3450	3450	3450	3450	3450
FLA	20	20	13.7	6.9	5.5	18.5	17	12.5	6.5	5
SFA	20	20	13.7	6.9	5.5	18.5	17	12.5	6.5	5
LRA	71.2	70	59.2	27.3	24	66.1	70	59.2	27.3	24
Max kW Input	3.9	4	4.3	4.3	4.3	3.3	3.7	3.5	3.4	3.4
Service Factor	1	1	1	1	1	1	1	1	1	1
Power Factor	.99	.99	.84	.82	.84	.99	.99	.89	.77	.76
KVA Code	G	H	L	L	P	G	H	L	L	P
Std. Impeller Diameter (in)	5.86	5.86	5.86	5.86	5.86	5.95	5.95	5.95	5.95	5.95
Shut-Off Head (ft)	185	185	185	185	185	110	110	110	110	110
Power Cord Type & Diameter	12/4 SOOW	12/4 SOOW	12/4 SOOW	12/4 SOOW	12/4 SOOW	12/4 SOOW	12/4 SOOW	12/4 SOOW	12/4 SOOW	12/4 SOOW

\* Single-phase motors require capacitors. Liberty Pumps control panel or capacitor kits are recommended for proper operation and warranty. Refer to "Control Panel" section.

<b>Motor Insulation Class</b>	1-phase - F 155°C 3-phase - B 130°C
<b>Impeller Type</b>	Open
<b>Impeller Material</b>	316 Stainless Steel
<b>Power Cord Length (Options)</b>	25, 35, 50 ft
<b>Quick-connect Cords</b>	Standard
<b>Upper Seal Material</b>	Silicon Carbide/Silicon Carbide HNBR Elastomers
<b>Lower Seal Material</b>	Double Lip Seal Viton Elastomers
<b>Max Water Temp for Continuous Duty</b>	40°C
<b>Min Fluid Level for Continuous Operation</b>	Motor Housing Fully Submerged
<b>Fluid pH Range</b>	4-10
<b>Shaft Material</b>	303 Stainless Steel
<b>Fastener Material</b>	Stainless Steel
<b>O-Ring Elastomers</b>	Buna-N
<b>Upper Bearing</b>	Radial Ball

<b>Lower Bearing</b>	Angular Contact Ball
<b>Oil Type</b>	ISO VG10 Turbine Oil
<b>Max Submersion Depth</b>	10 ft less than selected cord length (not to exceed 40 ft)
<b>Discharge</b>	1.25 in FNPT
<b>Protective External Finish</b>	Epoxy Powder Coat
<b>Seal Fail Detection</b>	No
<b>Thermal Protection</b>	1-phase - Direct Acting, 135°C 3-phase - none
<b>Motor Enclosure Material</b>	Class 25 Cast Iron
<b>Volute Material</b>	Class 25 Cast Iron
<b>Cuts Per Minute</b>	372,600
<b>Cutter Material</b>	440 Stainless Steel
<b>Pump Weight</b>	87 lbs (approx)
<b>Certifications</b>	CSA Certified to CSA and UL® Standards CAN/CSA C22.2 No. 108-14 ANSI/UL 778 6th Ed

Specifications are subject to change without notice.

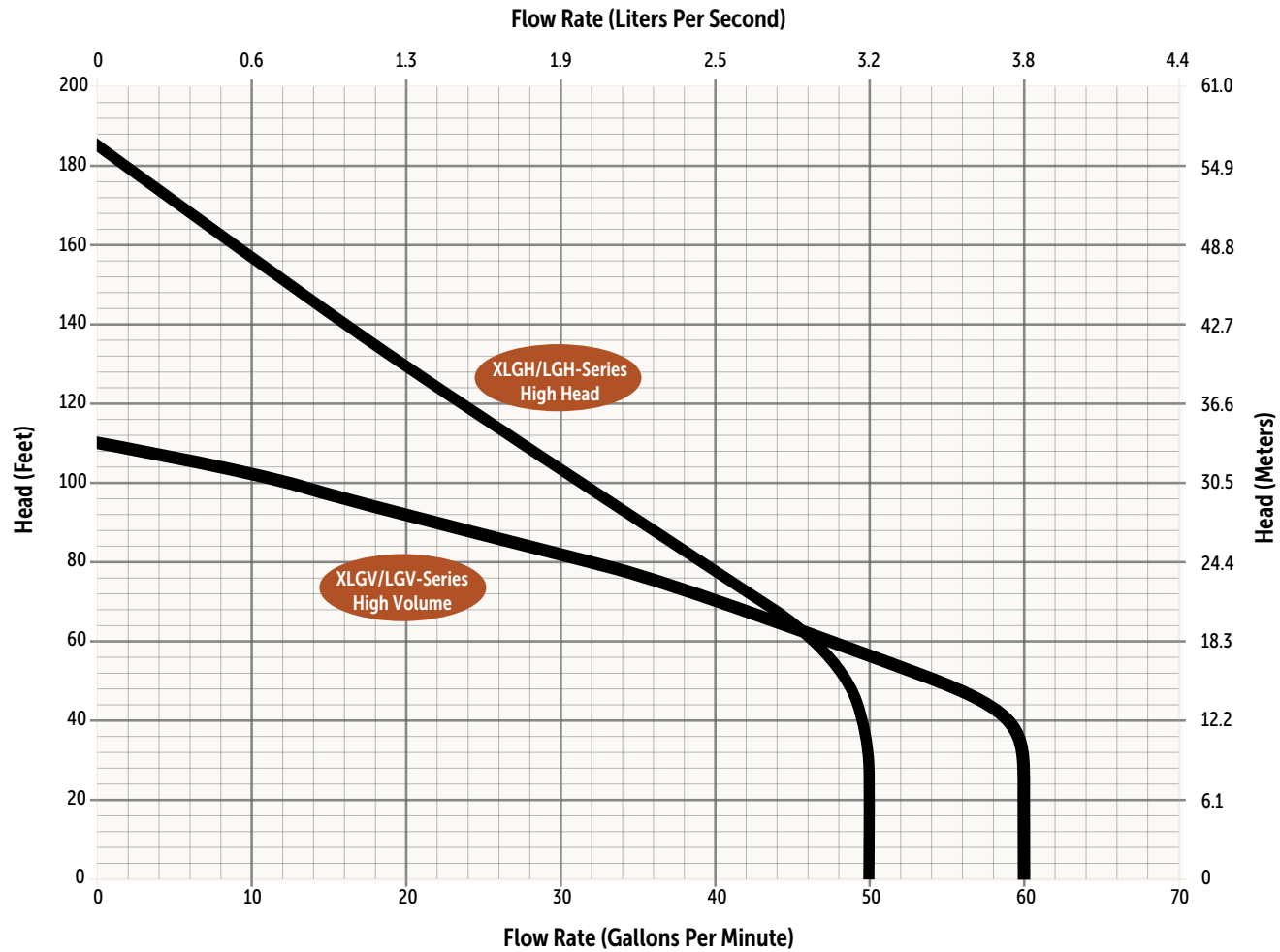

Pumps must operate within the proper range shown on the performance chart. It is the responsibility of the end user to ensure this requirement is met. Pumps operating outside the recommended range are prone to damage, excessive vibration, cavitation, poor efficiency, and may exceed nameplate amperage.

Specifications are subject to change without notice.

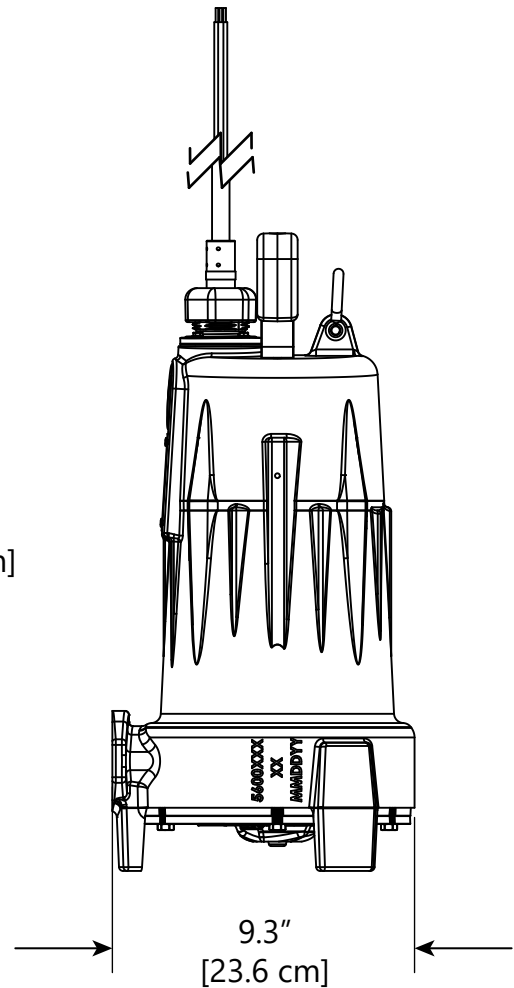
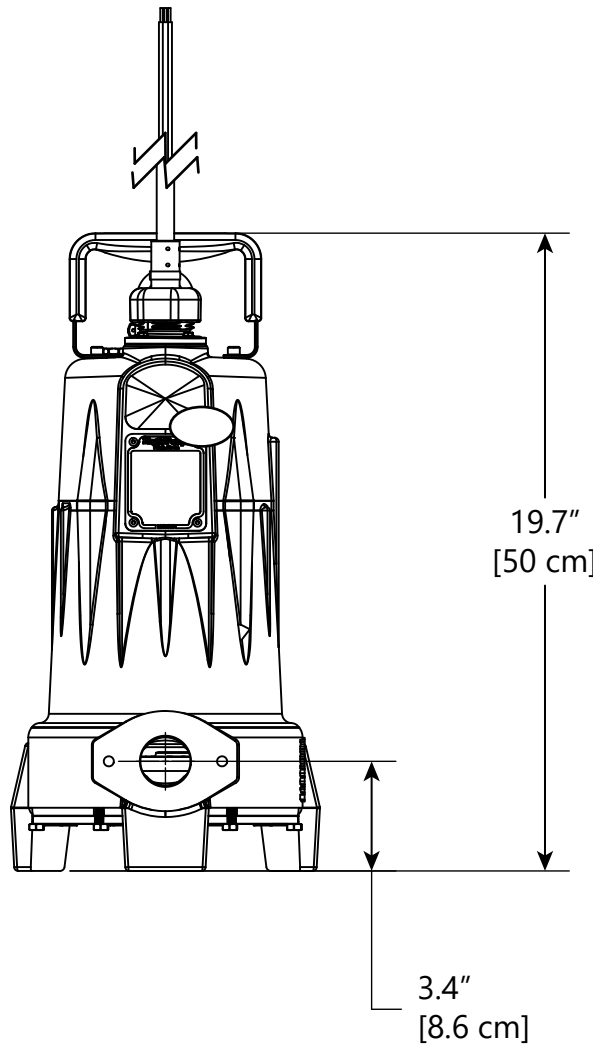
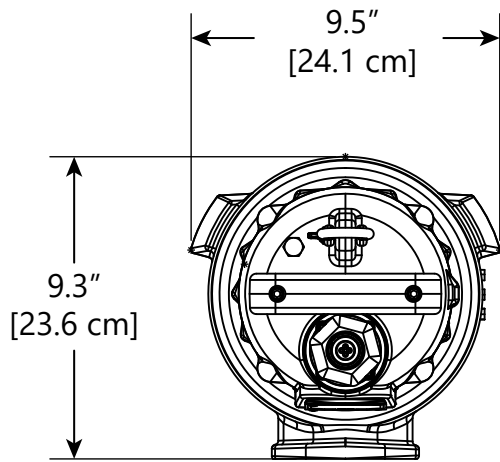

Specifications are subject to change without notice.



**Standard Panel  
(SX-Series shown)**

## STANDARD PANEL - SIMPLEX & DUPLEX

- Across-the-line magnetic contactor(s)
- Test/Auto switch(es)
- Terminal block
- Green pump run light(s)
- Alarm horn
- Red alarm indicator light or beacon
- Alarm silence and test switches
- Auxiliary contacts



**GR20-Series**

## GR20-SERIES

- Single guide pipe design with auto-align feature
- Powder coated for corrosion resistance
- Heavy nitrile sealing grommet
- Includes: mating flange, upper rail support bracket, stainless steel bolts and sealing grommet
- All cast iron
- 1-1/4" guide pipe threads FNPT
- 1-1/4" discharge threads FNPT



**G90-Series**

## G90-SERIES

- Fits 2.5 hp Omnivore® Series Grinders
- Provides vertical discharge for non-guide rail installations
- 1-1/4" female threaded outlet
- Heavy cast iron construction
- Powder coated for corrosion resistance
- Includes sealing grommet and stainless steel bolts

Specifications are subject to change without notice.

## GENERAL

---

The contractor shall provide labor, material, equipment, and incidentals required to provide \_\_\_\_\_ (QTY) sewage grinder pumps as specified herein. The pump models covered in this specification are high head models LGH028, LGH022, LGH023, LGH024, LGH025 and high volume models LGV028, LGV022, LGV023, LGV024, LGV025 grinder pumps. The pump furnished for this application shall be model \_\_\_\_\_ as manufactured by Liberty Pumps.

## OPERATING CONDITIONS

---

Each submersible pump shall be rated at 2.5 hp, \_\_\_\_\_ Volts, \_\_\_\_\_ phase, 60 Hz, 3450 RPM. The unit shall produce \_\_\_\_\_ GPM at \_\_\_\_\_ feet of total dynamic head.

The submersible pump shall be capable of handling residential and commercial sewage and grinding it to a fine slurry, enabling it to be pumped over long distances in pipelines as small as 2" in diameter. The LGH02-Series submersible pump shall have a shut-off head of 185 feet and a max flow of 50 GPM @ 10 feet of total dynamic head. The LGV02-Series submersible pump shall have a shut-off head of 110 feet and a max flow of 60 GPM @ 10 feet of total dynamic head.

## CONSTRUCTION

---

Each centrifugal sewage grinder pump shall be equal to the Certified LGH02/LGV02-Series pumps as manufactured by Liberty Pumps, Bergen NY. The casting enclosing the motor shall be constructed of class 25 cast iron. The motor housing shall be oil-filled to dissipate heat. Air-filled motors shall not be considered equal since they do not properly dissipate heat from the motor. Mating parts shall be machined and sealed with a Buna-N O-ring. All fasteners exposed to the process fluid shall be stainless steel. The motor shall be protected on the top side with a sealed cast iron cord entry plate, which is potted to prevent water from entering through the cord. The motor shall be protected on the lower side with a dual seal arrangement. The first seal shall be a double lip seal molded in elastomeric rubber. The second (main) seal shall be a unitized hard face silicon carbide seal with stainless steel housings and spring. The upper and lower bearings shall be capable of handling all radial thrust loads. The lower bearing shall have the additional ability to handle the downward axial thrust produced by the impeller and cutters by design of angular contact roller races. The pump housing shall be of a concentric design thereby equalizing the pressure forces inside the housing that will extend the service life of the seals and bearings. Additionally, there shall be no cutwater in the housing volute in order to discourage the entrapment of flowing debris. The pump shall be furnished with stainless steel handle having a nitrile grip.

## POWER AND CONTROL CORD

---

The submersible pump shall be supplied with 25, 35, or 50 feet of a multi-conductor cord of type SOOW. These type SOOW power cords carry a voltage rating of 600 V, a temperature rating of 90°C, have oil-resistant insulation, are water- and weather-resistant, UL listed, and CSA approved.

The power cord shall be sized for the rated full load amps of the pump for continuous duty in accordance with the NEC®.

Standard Quick-connect cord shall offer quick cord replacement without the need to send the entire pump to an authorized repair facility. This shall also allow for pump maintenance without disturbing electrical boxes or control panels.

## MOTOR

---

The motor shall be oil-filled, Class F (1-phase)/Class B (3-phase) insulated, and rated for continuous duty. Since air-filled motors are not capable of dissipating heat efficiently, they shall not be considered equal.

1-phase pump motors shall be capacitor start/capacitor run and have an integral thermal overload switch in the windings for protecting the motor. 3-phase motors shall be used with an appropriate controller with integral overload protection. On all 1-phase models, the capacitor circuit and start relay shall be mounted in a correctly sized control panel.

1-phase motor(s) copper stator windings shall be insulated with moisture-resistant Class F insulation materials, rated for 155°C. The maximum continuous temperature of pumped liquids shall be 40°C. The winding operating temperature at rated horsepower and service factor shall be a maximum of 135°C @ 40°C ambient.

3-phase motor(s) copper stator windings shall be insulated with moisture-resistant Class B insulation materials, rated for 130°C. The maximum continuous temperature of pumped liquids shall be 40°C. The winding operating temperature at rated horsepower and service factor shall be a maximum of 125°C @ 40°C ambient.

## BEARINGS AND SHAFT

---

The shaft shall be supported by two ball bearings. The top bearing shall be a single ball/race type bearing and the lower bearing shall be an angular contact ball bearing designed to handle the radial and axial forces incurred by pumping/grinding. Both bearings shall be permanently lubricated by the oil that fills the motor housing. Pump designs requiring scheduled bearing maintenance shall not be considered equal. Pumps with single row lower bearings or sleeve bearings shall not be considered equal. The bearing system shall be designed to enable proper cutter alignment from shutoff head to maximum load at 185 ft of TDH.

The motor shaft shall be made of 303 stainless steel. The shaft shall be designed to withstand the maximum torque and radial loads present during start-up and normal operation. Shafts of carbon steel or chrome-plated shafts shall not be considered equal.

## SEALS

The pump shall have a dual seal arrangement consisting of a lower and upper seal to protect the motor from the pumping liquid. The lower seal shall be a rubber molded double lip seal with Viton elastomers, designed to exclude foreign material away from the main upper seal. The upper seal shall be a unitized silicon carbide hard face seal with stainless steel housings and spring. The motor plate/housing interface shall be sealed with a Buna-N O-ring.

## CUTTER MECHANISM

The cutter and plate shall consist of hardened 440 stainless steel with a Rockwell C hardness of 58Rc. The stationary cutter plate shall have specially designed orifices through it, which enable the slurry to flow through the pump housing at an equalized pressure and velocity. The stationary cutter plate shall feature patented V-Slice® Cutter Technology. This superior cutting system consists of V shapes to maximize cutting action and arc shape exclusion slots to outwardly eject debris from under the rotary cutter. The rotary cutter shall have (4) blades and be designed with a recessed area behind the cutting edge to prevent the accumulation and binding of any material between rotary cutter and the stationary cutter plate. The cutter shall be capable of over 300,000 cuts per minute. The cutting system shall incorporate close tolerances for optimum performance. Ring or radial cutters, or those that grind on the outside circumference of shall not be considered equal.

## IMPELLER

The impeller shall be 316 Stainless Steel. The impeller shall be keyed and bolted onto the motor shaft.

## CONTROL PANEL

All LGH02/LGV02-Series pumps require a control panel. The control panel shall be equipped with circuit breakers and adjustable overload devices to protect against excess current or electrical problems. This device shall be sized appropriately for the pump model(s) being controlled.

The control panel for 1-phase models shall include a motor start circuit that automatically engages and disengages the start windings of the 1-phase motor. The motor start circuit shall consist of a properly sized relay which engages and disengages the motor start windings. A solid state start switch shall monitor start winding voltage and shall control the aforementioned relay. The start and run capacitors shall be properly sized per the motor specifications. A bleed resistor shall be used on the start capacitor to avoid unwanted voltage spikes during startup. Capacitor start/run components (Kit#K001640, 200V; #K001614, 230V) are available for 1-phase models using a non-Liberty Pumps control panel.

Pump Model	Voltage	Control Panel Model		
		Simplex 3-Float	Duplex 3-Float	Duplex 4-Float
LGH028	200	SX24HS1=3	AE24HS2=3	AE24HS2=4
LGH022	230	SX24HS1=3	AE24HS2=3	AE24HS2=4
LGH023	200/230	SX34=3-511	AE34=3-511	AE34=4-511
LGH024	460	SX34=3-191	AE34=3-191	AE34=4-191
LGH025	575	SX54=3-161	AE54=3-161	AE54=4-161
LGV028	200	SX24HS1=3	AE24HS2=3	AE24HS2=4
LGV022	230	SX24HS1=3	AE24HS2=3	AE24HS2=4
LGV023	200/230	SX34=3-511	AE34=3-511	AE34=4-511
LGV024	460	SX34=3-191	AE34=3-191	AE34=4-191
LGV025	575	SX54=3-161	AE54=3-161	AE54=4-161

## QUALITY CONTROL

The pump shall be manufactured in an ISO® 9001 certified facility. Manufactured in the USA with US and global components.

## SUPPORT

The pump shall have cast iron support legs, enabling it to be a freestanding unit. The legs shall be high enough to allow solids and long stringy debris to enter the pump inlet.

## PROTECTIVE FINISH

The exterior of the casting shall be protected with corrosion-resistant baked-on epoxy powder coat.

## TESTING

The pump shall have a ground continuity check and undergo a hi-pot test for electrical integrity, moisture content, and insulation defects. The motor housing shall be pressurized, and an air leak decay test performed to ensure integrity of the assembled unit. The pump shall be run, voltage and current monitored, and checked for noise or other malfunction. Certified performance testing is available upon request.



## APPLICATIONS

---

- Municipal Engineered Lift Stations
- Storm Water Removal
- Wastewater Transfer
- Industrial Wastewater
- Treatment Plants

## MATERIAL FEATURES

### PUMP:

---

- Grinder - High Head or High Volume
- Discharge - Horizontal, 1.25" FNPT
- Seals - Dual, Upper - Silicon Carbide/Silicon Carbide with HNBR Elastomers;  
Lower - Double Lip Seal with Viton Elastomers
- Construction - Cast Iron ASTM A48, Class 25A, 25,000# Tensile Strength,  
Protected with a Corrosion-Resistant Baked-on Epoxy Powder Coating
- Hardware - Stainless Steel
- O-ring Seals - Buna-N
- Impeller - 316 Stainless Steel
- Cutter and Cutter Plate - Hardened 440 Stainless Steel
- Cuts per minute - 372,600
- Thermal Sensors (1-phase only)
- Optional:
  - Cord Length Options (feet) - 25, 35, 50

### MOTOR:

---

- 1-Phase - 200, 230 Volt, 3450 RPM
- 3-Phase - 200/230, 460, 575 Volt, 3450 RPM
- Oil-filled Motor Housing
- Continuous Duty Operation
- Bearings
  - Upper - Radial Ball
  - Lower - Angular Contact Ball

## LIMITED WARRANTY

---

Liberty Pumps, Inc. warrants that pumps of its Engineered Product line are free from all factory defects in material and workmanship for a period of 18 months from the date of installation or 24 months from the date of manufacture, whichever occurs first, and provided that such products are used in compliance with their intended applications as set forth in the Liberty Engineered Products specifications and technical manuals. The date of installation shall be determined by a completed pump start-up report and warranty registration form.

A pump startup report, filled out by a qualified installer, is required for warranty to take effect. The report must be submitted within 30 days from the installation date and submitted through the Liberty Pumps website. During the warranty period, the manufacturer's obligation, and at its discretion, shall be limited to the repair or replacement of any parts found by the manufacturer to be defective, provided the product is returned freight prepaid to the manufacturer or its authorized service center, and provided that none of the following warranty-voiding characteristics are evident:

The manufacturer shall not be liable under this Warranty if the product has not been properly installed or maintained in accordance with the printed instructions provided; if it has been disassembled, modified, abused or tampered with; if the pump discharge has been reduced in size; if the pump has been used in water temperatures above those shown in the specifications; if the thermal overload(s) and seal moisture probe(s) have not been properly connected (where equipped); if the pump has been used in water containing sand, lime, cement, gravel or other abrasives; if the product has been used to pump chemicals or hydrocarbons; if the product has been moved from its original installation location, or if the label bearing the serial and code number has been removed.

Liberty Pumps, Inc. shall not be liable for any loss, damage or expenses resulting from installation or use of its products, or for consequential damages, including field labor costs, travel expenses, rental equipment, costs of removal, reinstallation or transportation to and from the factory or an authorized Liberty Pumps repair facility.

There is no other express warranty. All implied warranties, including those of merchantability and fitness for a particular purpose, are limited to 18 months from the date of installation or 24 months from the manufacturing date. This Warranty contains the exclusive remedy of the purchaser, and, where permitted, liability for consequential or incidental damages under any and all warranties are excluded.